

CC4600 Series

1/3-inch Color Cameras

Installation/Operation Manual

C1902M (11/96)

TABLE OF CONTENTS

<u>Section</u>	<u>Page</u>
1.0 IMPORTANT SAFEGUARDS	1
1.1 FCC INFORMATION	2
1.2 SAFETY PRECAUTIONS	2
1.3 UNPACKING	2
2.0 DESCRIPTION	3
2.1 LOCATION AND FUNCTION OF PARTS	4
2.1.1 Top/Front/Side (Illustration A)	4
2.1.2 Rear (Illustration B)	5
3.0 POWER SUPPLY CONSIDERATIONS	6
4.0 LENSES	8
4.1 LENS LIMITS	8
4.2 LENS COMPATIBILITY	8
4.3 LENS INSTALLATION	9
4.3.1 Auto Iris	9
4.3.2 Manual Iris	9
5.0 CAMERA INSTALLATION	14
5.1 CONNECTIONS (Illustration F)	14
5.2 PHASE ADJUSTMENT (Illustration G)	14
5.3 VERTICAL PHASE (Illustration H)	14
6.0 CCD CHARACTERISTICS	15
7.0 HOUSEKEEPING	15
7.1 OPERATION AND STORAGE LOCATIONS	15
7.2 CARE OF THE UNIT	15
8.0 MAINTENANCE	15
9.0 SPECIFICATIONS	16
10.0 WARRANTY AND RETURN INFORMATION	18

LIST OF FIGURES AND ILLUSTRATIONS

<u>Figure</u>	<u>Page</u>
1 The CC4600 Series Camera	3
2 Rear Panels: CC4600-2/-2X and CC4600-3	6
3 Typical 120 VAC to 24 VAC (60Hz) Power Supply	7
4 Typical 230 VAC to 24 VAC (50 Hz) Power Supply	7
5 Standard Acceptable Lens Dimensions	8
6 CC4600 Series Dimension Drawing	16

<u>Illustrations</u>	<u>Page</u>
A Top/Front/Side View of CC4600 Series Cameras	4
B Rear View of CC4600 Series Cameras	5
C Compatible Lenses	8
D Changing the Plug on an Auto Iris Lens Cable	9
E Fitting the Lens	13
F Connecting the CC4600 Cameras	14
G Phase Adjustment	15
H Vertical Phase	15

®Pelco and the Pelco logo are registered trademarks of Pelco.
 ©Copyright 1996, Pelco. All rights reserved.

1.0 IMPORTANT SAFEGUARDS

1. Read Instructions - All the safety and operating instructions should be read before the unit is operated.
2. Retain Instructions - The safety and operating instructions should be retained for future reference.
3. Heed Warnings - All warnings on the unit and in the operating instructions should be adhered to.
4. Follow Instructions - All operating and use instructions should be followed.
5. Cleaning - Unplug the unit from the outlet before cleaning. Do not use liquid cleaners or aerosol cleaners. Use a damp cloth for cleaning.
6. Attachments - Do not use attachments not recommended by the product manufacturer as they may cause hazards.
7. Water and Moisture - Do not use this unit near water - for example, near a bath tub, wash bowl, kitchen sink, or laundry tub, in a wet basement, near a swimming pool, in an unprotected outdoor installation, or any area which is classified as a wet location.
8. Accessories - Do not place this unit on an unstable stand, tripod, bracket, or mount. The unit may fall, causing serious injury to a person and serious damage to the unit. Use only with a stand, tripod, bracket, or mount recommended by the manufacturer, or sold with the product. Any mounting of the unit should follow the manufacturer's instructions, and should use a mounting accessory recommended by the manufacturer.

An appliance and cart combination should be moved with care. Quick stops, excessive force, and uneven surfaces may cause the appliance and cart combination to overturn.



9. Ventilation - Openings in the enclosure, if any, are provided for ventilation and to ensure reliable operation of the unit and to protect it from overheating. These openings must not be blocked or covered. This unit should not be placed in a built-in installation unless proper ventilation is provided or the manufacturer's instructions have been adhered to.
10. Power Sources - This unit should be operated only from the type of power source indicated on the marking label. If you are not sure of the type of power supply you plan to use, consult your appliance dealer or local power company. For units intended to operate from battery power, or other sources, refer to the operating instructions.
11. Grounding or Polarization - This unit may be equipped with a polarized alternating-current line plug (a plug having one blade wider than the other). This plug will fit into the power outlet only one way. This is a safety feature. If you are unable to insert the plug fully into the outlet, try reversing the plug. If the plug should still fail to fit, contact your electrician to replace your obsolete outlet. Do not defeat the safety purpose of the polarized plug.

Alternately, this unit may be equipped with a 3-wire grounding-type plug, a plug having a third (grounding) pin. This plug will only fit into a grounding-type power outlet. This is a safety feature. If you are unable to insert the plug into the outlet, contact your electrician to replace your obsolete outlet. Do not defeat the safety purpose of the grounding-type plug.

12. Power-Cord Protection - Power supply cords should be routed so that they are not likely to be walked on or pinched by items placed upon or against them, paying particular attention to cords and plugs, convenience receptacles, and the point where they exit from the appliance.
13. Power Lines - An outdoor system should not be located in the vicinity of overhead power lines or other electric light or power circuits, or where it can fall into such power lines or circuits. When installing an outdoor system, extreme care should be taken to keep from touching such power lines or circuits as contact with them might be fatal. U.S.A. models only - refer to the National Electrical Code Article 820 regarding installation of CATV systems.
14. Overloading - Do not overload outlets and extension cords as this can result in a risk of fire or electric shock.
15. Object and Liquid Entry - Never push objects of any kind into this unit through openings as they may touch dangerous voltage points or short-out parts that could result in a fire or electric shock. Never spill liquid of any kind on the unit.
16. Servicing - Do not attempt to service this unit yourself as opening or removing covers may expose you to dangerous voltage or other hazards. Refer all servicing to qualified service personnel.
17. Damage Requiring Service - Unplug the unit from the outlet and refer servicing to qualified service personnel under the following conditions:
 - a. When the power-supply cord or plug is damaged.
 - b. If liquid has been spilled, or objects have fallen into the unit.
 - c. If the unit has been exposed to rain or water.
 - d. If the unit does not operate normally by following the operating instructions. Adjust only those controls that are covered by the operating instructions, as an improper adjustment of other controls may result in damage and will often require extensive work by a qualified technician to restore the unit to its normal operation.
 - e. If the unit has been dropped or the cabinet has been damaged.
 - f. When the unit exhibits a distinct change in performance - this indicates a need for service.
18. Replacement Parts - When replacement parts are required, be sure the service technician has used replacement parts specified by the manufacturer or have the same characteristics as the original part. Unauthorized substitutions may result in fire, electric shock or other hazards.
19. Safety Check - Upon completion of any service or repairs to this unit, ask the service technician to perform safety checks to determine that the unit is in proper operating condition.
20. Coax Grounding - If an outside cable system is connected to the unit, be sure the cable system is grounded. U.S.A. models only-Section 810 of the National Electrical Code, ANSI/NFPA No.70-1981, provides information with respect to proper grounding of the mount and supporting structure, grounding of the coax to a discharge unit, size of grounding conductors, location of discharge unit, connection to grounding electrodes, and requirements for the grounding electrode.
21. Lightning - For added protection of this unit during a lightning storm, or when it is left unattended and unused for long periods of time, unplug it from the wall outlet and disconnect the cable system. This will prevent damage to the unit due to lightning and power-line surges.

1.1 FCC INFORMATION

For USA customers

WARNING - This equipment has been tested and found to comply with the limits for a Class B digital device, pursuant to Part 15 of the FCC Rules. These limits are designed to provide reasonable protection against harmful interference when the equipment is operated in a residential installation. This equipment generates, uses and can radiate radio frequency energy and, if not installed and used in accordance with the instructions, may cause harmful interference to radio communications. However, there is no guarantee that interference will not occur in a particular installation. If this equipment does cause harmful interference to radio or television reception, which can be determined by turning the equipment off and on, the user is encouraged to try to correct the interference by one or more of the following measures:

- Reorient or relocate the receiving antenna.
- Increase the separation between the equipment and receiver.
- Connect the equipment into an outlet on a circuit different from that to which the receiver is connected.
- Consult the dealer or an experienced audio/TV technician for help.

Intentional or unintentional changes or modifications not expressly approved by the party responsible for compliance shall not be made. Any such changes or modifications could void the user's authority to operate the equipment.

The user may find the following booklet prepared by the Federal Communications Commission helpful: "How to Identify and Resolve Radio-TV Interference Problems". This booklet is available from the U.S. Government Printing Office, Washington, DC 20402, Stock No. 004-000-00345-4.

For United Kingdom customers

WARNING
THIS APPARATUS MUST BE EARTHED

IMPORTANT

The wires in the power supply lead are colored in accordance with the following code:

Green-and-yellow:	Earth
Blue:	Neutral
Brown:	Live

As the colors of the wires in the power lead of this apparatus may not correspond with the colored markings identifying the terminals in your plug proceed as follows:

The wire which is colored green-and-yellow must be connected to the terminal in the plug which is marked by the letter E or by the safety earth symbol  or colored green or green-and-yellow.

The wire which is colored blue must be connected to the terminal which is marked with the letter N or colored black.

The wire which is colored brown must be connected to the terminal which is marked with the letter L or colored red.

1.2 SAFETY PRECAUTIONS



This label may appear on the bottom of the unit due to space limitations.

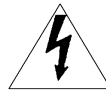

The lightning flash with an arrowhead symbol, within an equilateral triangle, is intended to alert the user to the presence of uninsulated "dangerous voltage" within the product's enclosure that may be of sufficient magnitude to constitute a risk of electric shock to persons.



The exclamation point within an equilateral triangle is intended to alert the user to presence of important operating and maintenance (servicing) instructions in the literature accompanying the appliance.

Warning
To prevent fire or shock hazard, do not expose units not specifically designed for outdoor use to rain or moisture.

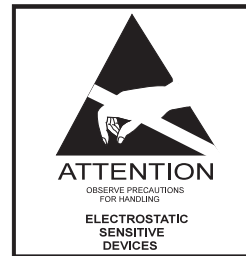

WARNING: Electrostatic-sensitive device. Use proper CMOS/MOSFET handling precautions to avoid electrostatic discharge.

NOTE: Grounded wrist straps must be worn and proper ESD safety precautions observed when handling the electrostatic-sensitive printed circuit boards.

1.3 UNPACKING

The shipping carton is the safest container in which the unit may be transported. Save it for possible future use.

Supplied

Accessories: 4-pin plug for auto iris lens (1); Operating Instructions (1)

2.0 DESCRIPTION

The CC4600 series cameras are compact, rugged, full performance general purpose color CCD cameras. Contemporary styling and concealed controls allow these cameras to blend naturally into the most modern installation sites. These cameras are 1/3-inch image format and are available in the following models:

NOTE: The alphanumeric reference designations (of the form **A**) used in this manual, are keyed to the reference designations used in the instruction sheets shipped with the product received by the customer.

Model #	Voltage	Voltage Range	Nominal Power	Color
CC4600-2	24 VAC	21 to 28	4.5 W	NTSC/EIA (60 Hz) 470TVL
CC4600-2X	24 VAC	21 to 28	4.5 W	PAL/CCIR (50 Hz) 470TVL
CC4600-3	230 VAC	198 to 264	5.5 W	PAL/CCIR (50 Hz) 470TVL

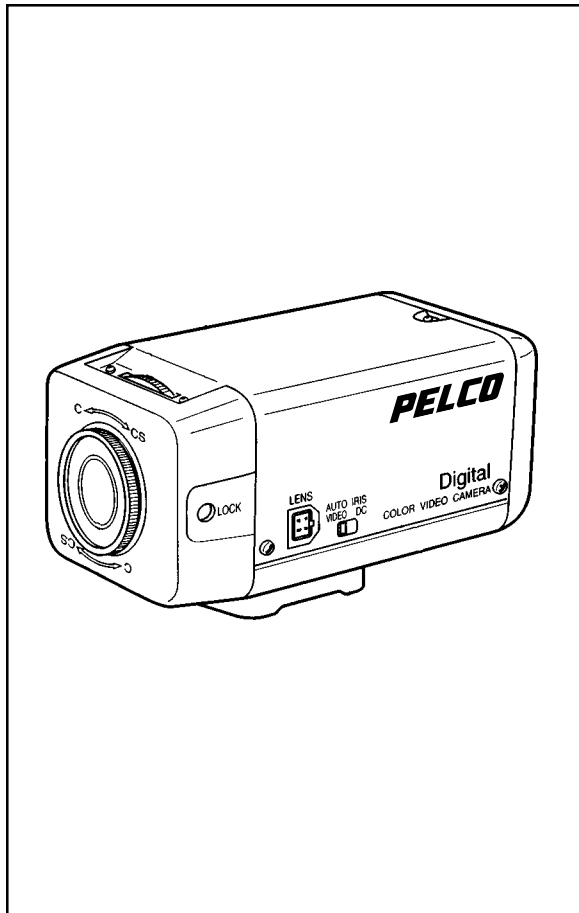

Figure 1. The CC4600 Series Camera

These model cameras all have the following features in common:

- High sensitivity (minimum illumination: 1.9 lux, F1.2)
- CCD camera with electronic iris function
- Automatic white balance tracking and adjustment (normal/PRO)
- Compatibility with DC controlled or video signal controlled auto iris lenses
- Automatic backlight compensation and automatic flicker reduction (operates when AGC switch is in the "ON" position)
- Line lock function for synchronizing through AC power source

2.1 LOCATION AND FUNCTION OF PARTS

2.1.1 Top/Front/Side (Illustration A)

- 1 Focal length adjustment ring and locking screw
Use this ring to adjust the focal length (the distance between the lens mounting plane and the image plane). Use the locking screw to lock the focal length.
- 2 Lens mount
Use to mount an appropriate C-mount or a CS-mount lens. To attach a C-mount/CS-mount lens, turn the focal length adjustment ring to the appropriate position. The factory setting is C mount.
- 3 Lens connector (4 pin socket)
Supplies power and control signals to an auto iris lens.
- 4 Camera mounting bracket
The mounting bracket can be attached to either the top or bottom of the camera using the four attached screws (1/4" UNC-20).

- 5 Auto iris lens selection switch (DC/Video)
Switch for selecting the control signal for the auto iris lens.
DC: For auto iris lenses controlled by DC signals
VIDEO: For auto iris lenses controlled by video signals

NOTE: If you use the electronic iris function in locations where the camera is exposed to fluorescent light, a slow color change may occur.

NOTES: When the DC/VIDEO switch is set to VIDEO, the backlight compensation function may not work properly.

When the DC/VIDEO switch is set to VIDEO, "hunting" may occur. If this occurs, use the LEVEL L/H adjustment screw on the lens to change the incident light level. When adjusting the incident light level, set the ALC (Automatic Light Control) adjustment screw to Av.

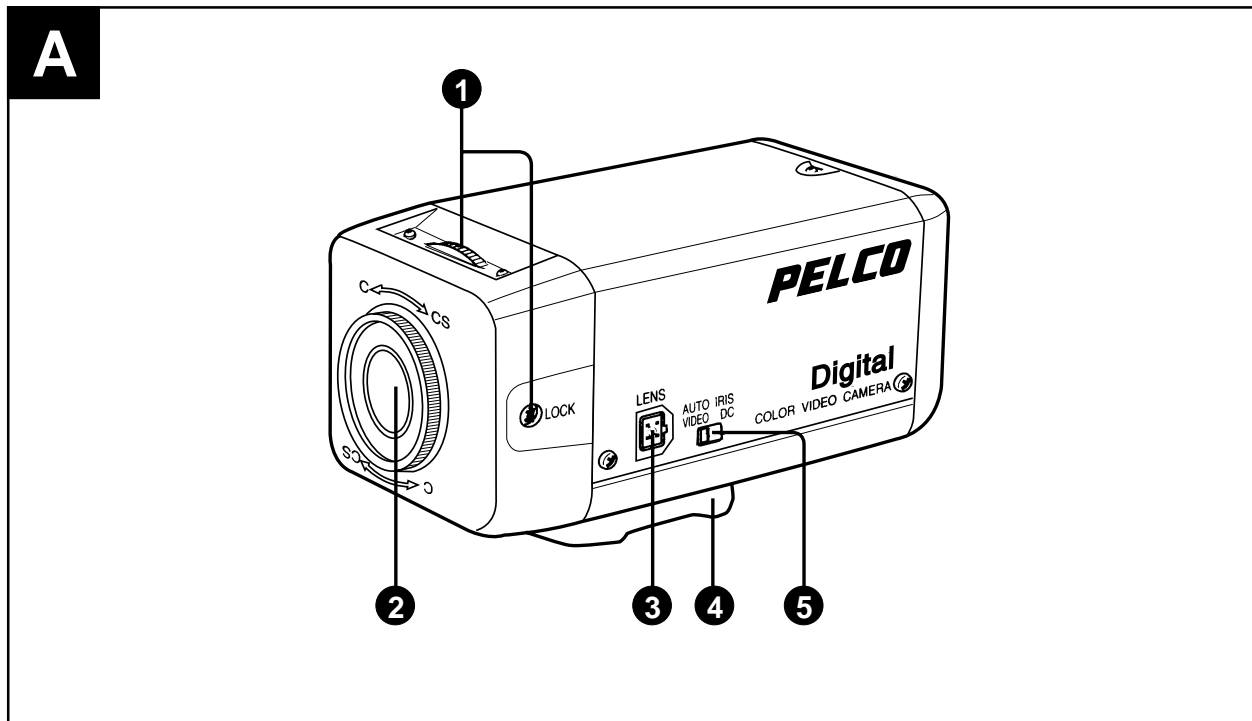

Top/Front/Side View of CC4600 Series Camera

2.1.2 Rear (Illustration B)

- 6 SYNC switch
Use this switch to set the camera synchronization mode—line lock (L.L) or internal (INT).
- 7 AGC (automatic gain control) ON/OFF switch
The automatic gain function automatically adjusts picture gain in accordance with the brightness of the subject.
- 8 Gain up switch
Switching the Gain up switch to the TURBO mode while the AGC switch is on increases gain by up to 6dB over the NORM (normal) mode.
- 9 BLC (back lighting compensation) ON/OFF switch
When switched on, this function adjusts exposure to compensate for situations where the subject is lit from behind.

NOTE: When the BLC is in the “ON” position, hunting may occur; that is, the image may get darker and lighter as the camera “hunts” for the best exposure level. If hunting occurs, set the BLC switch to “OFF”.

- 10 CCD-IRIS ON/OFF switch
When using a manual iris lens, the CCD-IRIS function automatically adjusts the shutter speed to maintain a suitable exposure level. Set switch to OFF if using an auto-iris lens..

- 11 White balance mode switch
When set in the ATW (auto tracing white balance) - PRO position, the camera automatically adjusts white balance to suit the color temperature of various lighting sources, including incandescent, fluorescent and natural lighting.

When set to the ATW position, the camera automatically adjusts white balance to suit special lighting sources such as sodium lamps.

- 12 Aperture switch
Set in the “SHARP” mode to sharpen the outline and produce a clearer picture.
- 13 VIDEO OUT connector (BNC)
- 14 Ground terminal (screw type)
- 15 Power cable (model CC4600-3 only)
- 16 24 VAC input terminals (models CC4600-2, CC4600-2X)
- 17 Video level adjustment pot
Use to adjust the video level when using a DC servo lens. If using a Video servo lens , turn the control toward the H (high) side.
- 18 Vertical phase adjustment pot
Use to adjust the vertical phase of cameras synchronized by line lock.

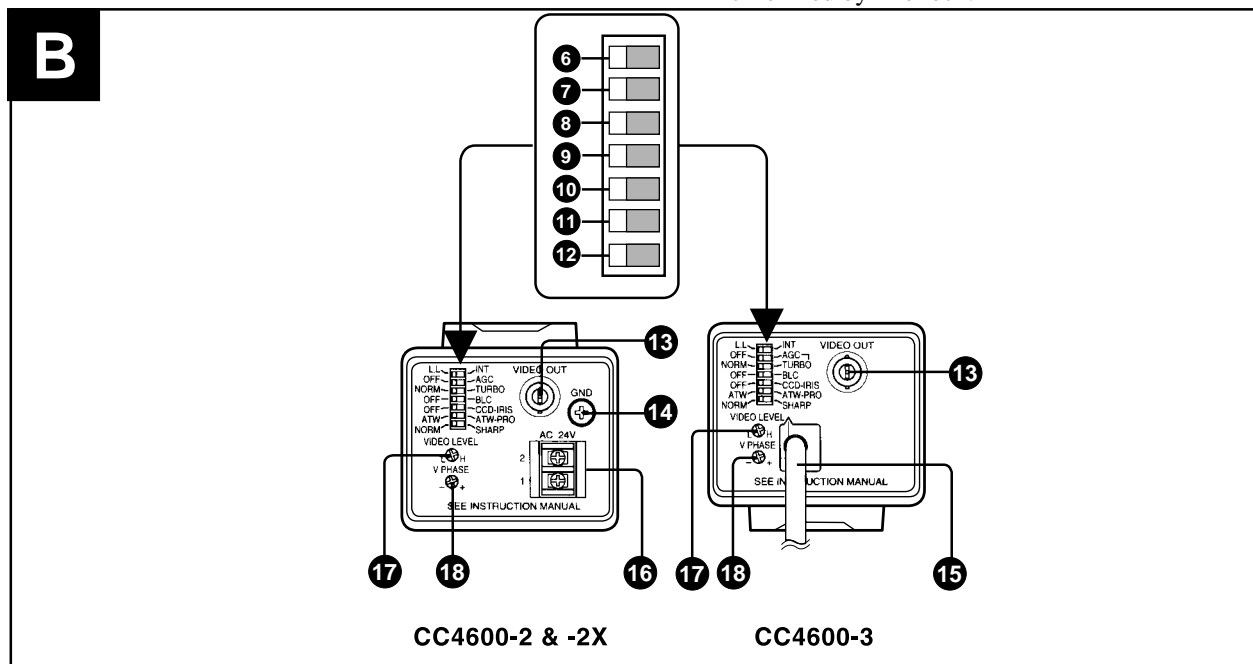

Rear View of CC4600 Series Cameras

3.0 POWER SUPPLY CONSIDERATIONS

Use only the recommended power supplies. Improper substitutions may damage the camera or cause a shock or fire hazard.

CC4600-2/2X

- The CC3300-2 must always be operated with a **24 VAC, Class 2 (60 Hz)** power supply (not supplied). A wall transformer (as depicted in Figure 3) is an example of a common power source.
- In the USA, use a power supply which is UL Listed. In Canada, use a power supply which is CSA Certified.
- The CC4600-2X must always be operated with a **24 VAC (50 Hz)** power supply.
- When connecting to the transformer, be sure to carefully connect each lead to the appropriate terminal. Wrong connections may cause malfunction and/or damage to video camera.
- Ground the unit or an irregular voltage may be generated in the AC power cord and may cause malfunction or damage to the video camera.
- 24 VAC Cameras: **do not exceed 24 VAC input.** Normal input voltage is 24 VAC

The power runs for user supplied wiring from a 24 VAC supply to a CC3300-2 camera should be within the following limits:

- Up to 60 m (200 ft) — 1 mm² (18 AWG) or larger.
- Up to 100 m (325 ft) — 1.5 mm² (16 AWG) or larger

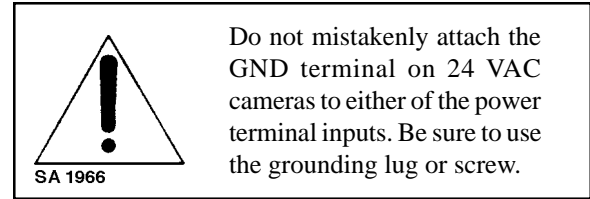

CC4600-3

- The CC3300-3 must be always operated with a **220-240 VAC, (50 Hz)** power supply.

NOTE: The CC4600-3 is supplied with an attached main power cable cord. See Figure 2 legend for power connections.

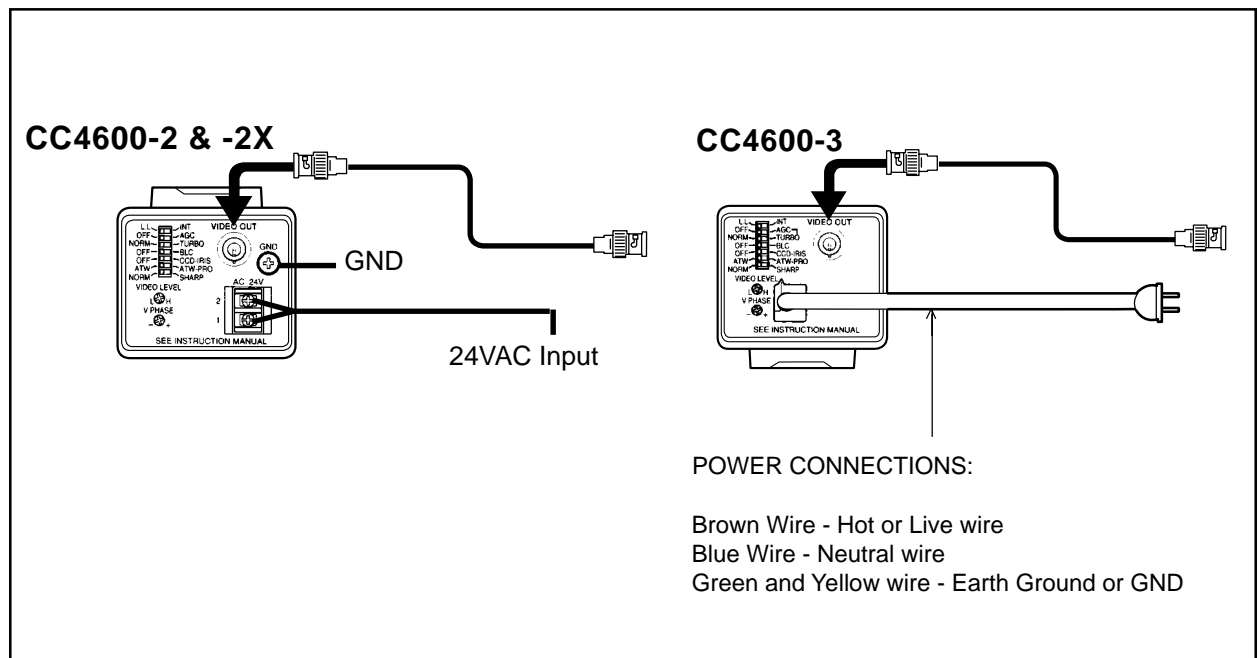

Figure 2. Rear Panels: CC4600-2/-2X and CC4600-3

- 120 VAC power source: The 24 VAC CC4600-2 camera must be wired to a 60 Hz source.

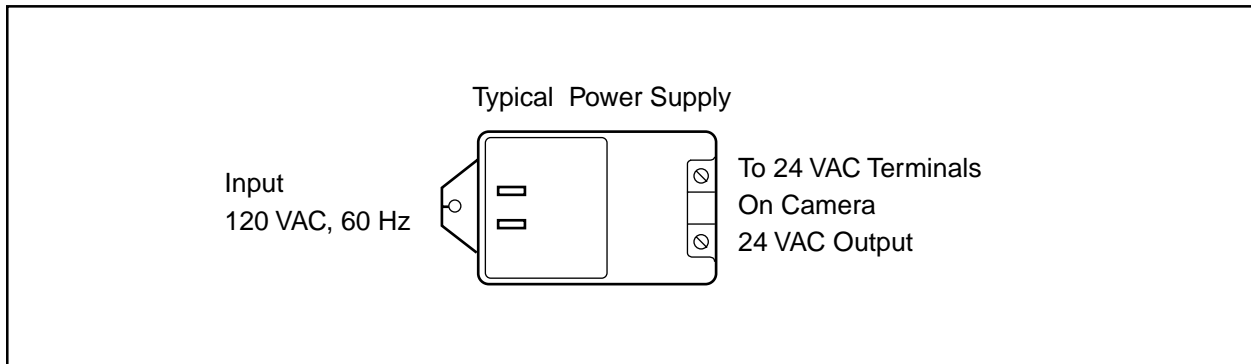

Figure 3. Typical 120 VAC to 24 VAC (60 Hz) Power Supply

- 230 VAC power source: The 24 VAC CC4600-2X and the 230 VAC CC4600-3 must be wired to a 50 Hz source.

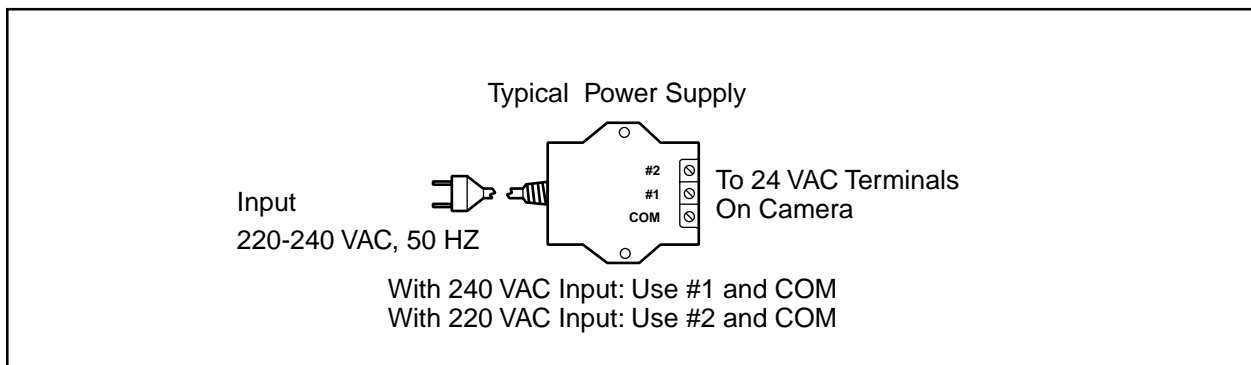

Figure 4. Typical 230 VAC to 24 VAC (50 Hz) Power Supply

NOTE: Cameras with 220-240 VAC power cords are double insulated. Article 250-45 of the National Electrical Code states that listed products protected by a system of double insulation shall not be required to be grounded.

4.0 LENSES

4.1 LENS LIMITS

Lenses exceeding the dimensions shown in Figure 5 below cannot be used.

When the lens is not mounted on the camera head, be sure to install the dust cap to protect the internal parts from dust or damage.

4.2 LENS COMPATIBILITY

(Illustration **C**)

The lens must be either a C- or a CS-mount type weighing less than 1 kg (2.2 lbs). The protrusion behind the mounting surface must be within the following limits:

1 C-mount lens	3 CS-mount lens
2 9 mm or less	4 4 mm or less

NOTE: Lenses that are suitable for a 1/3-inch CCD should be used with this camera using C or CS type lens mounts. Pelco 1/3" format lenses are recommended for optimum performance. The use of other lenses may impair camera performance. When lenses for a 2/3-inch or 1/2-inch CCD are used, the viewing angle will be slightly different.

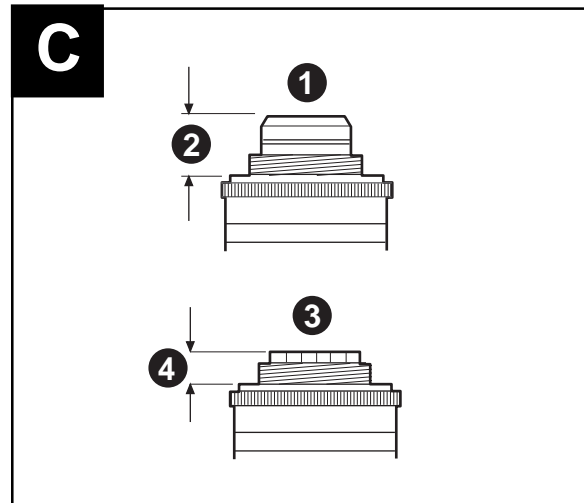

Compatible Lenses

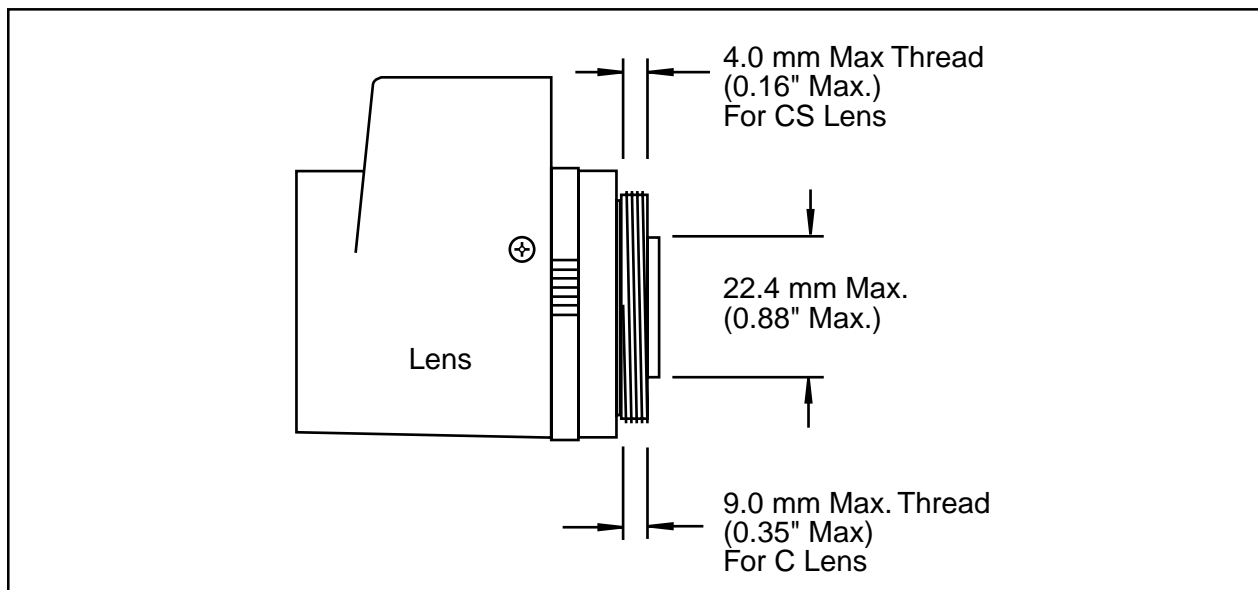

Figure 5. Standard Acceptable Lens Dimensions

4.3 LENS INSTALLATION

4.3.1 Auto Iris

Install an auto-iris lens as follows:
(Refer to Illustration **E**)

1. Unscrew lens mount cap.
2. Screw in the lens.
3. Check the plug wiring on the lens cable against Illustration **D** and the pin-outs mentioned in the Information Box below. If you need to replace the existing plug on the lens cable, follow the instructions given.
4. As part of lens installation, you need to adjust backfocusing. Follow the appropriate instructions found in the Information Boxes on pages 11 and 12. Background “General Information”, if needed, is provided on page 10.
5. Once adjusted, tighten the backfocus LOCK screw. (The factory setting is C-mount.)

NOTE: When attaching a C-mount type lens, be sure to turn the C/CS adjustment ring fully in the “C” direction. When the C/CS adjustment ring is set to “CS,” mounting any lens with a mount projection of more than 4 mm may damage the internal parts of the camera.

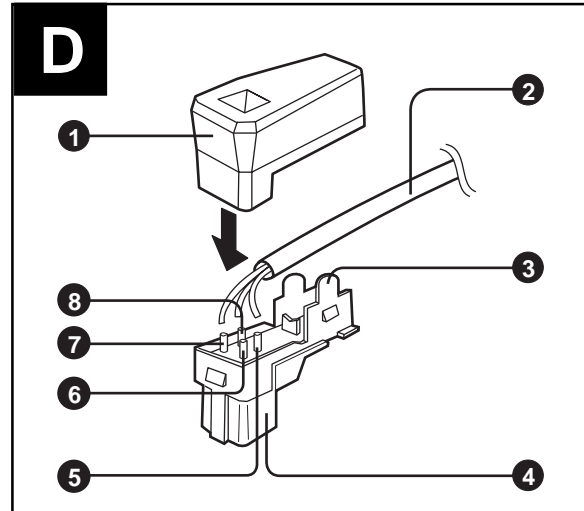

Changing the Plug on an Auto Iris Lens Cable

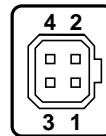

Auto Iris Plug
Pin-out (Back of Plug)

4.3.2 Manual Iris

Follow the instructions of the previous section but ignore all instructions for changing the lens cable plug.

Information Box Plug Change on Auto Iris Lens Cable Information Box

1. Remove the plug cover **1** and solder the lens cable wires **2** to the pins **5** thru **8** on the plug supplied. The pin assignments are as follows:

Pin #	DC-servo Lens	VS-servo Lens
Pin 3: 8	DRV+	Video signal
Pin 1: 7	CONT-	Power supply
Pin 2: 6	CONT+	Not Used
Pin 4: 5	DRV-	Ground

2. Put the cover on the plug.

ILLUSTRATION **D** ELEMENTS

- 1** Cover
- 2** Auto-iris cable
- 3** Rib (If the cable is thick and the plug cover does not seat properly, cut away this rib.)
- 4** Lens plug

CAMERA/LENS GEOMETRY—GENERAL INFORMATION

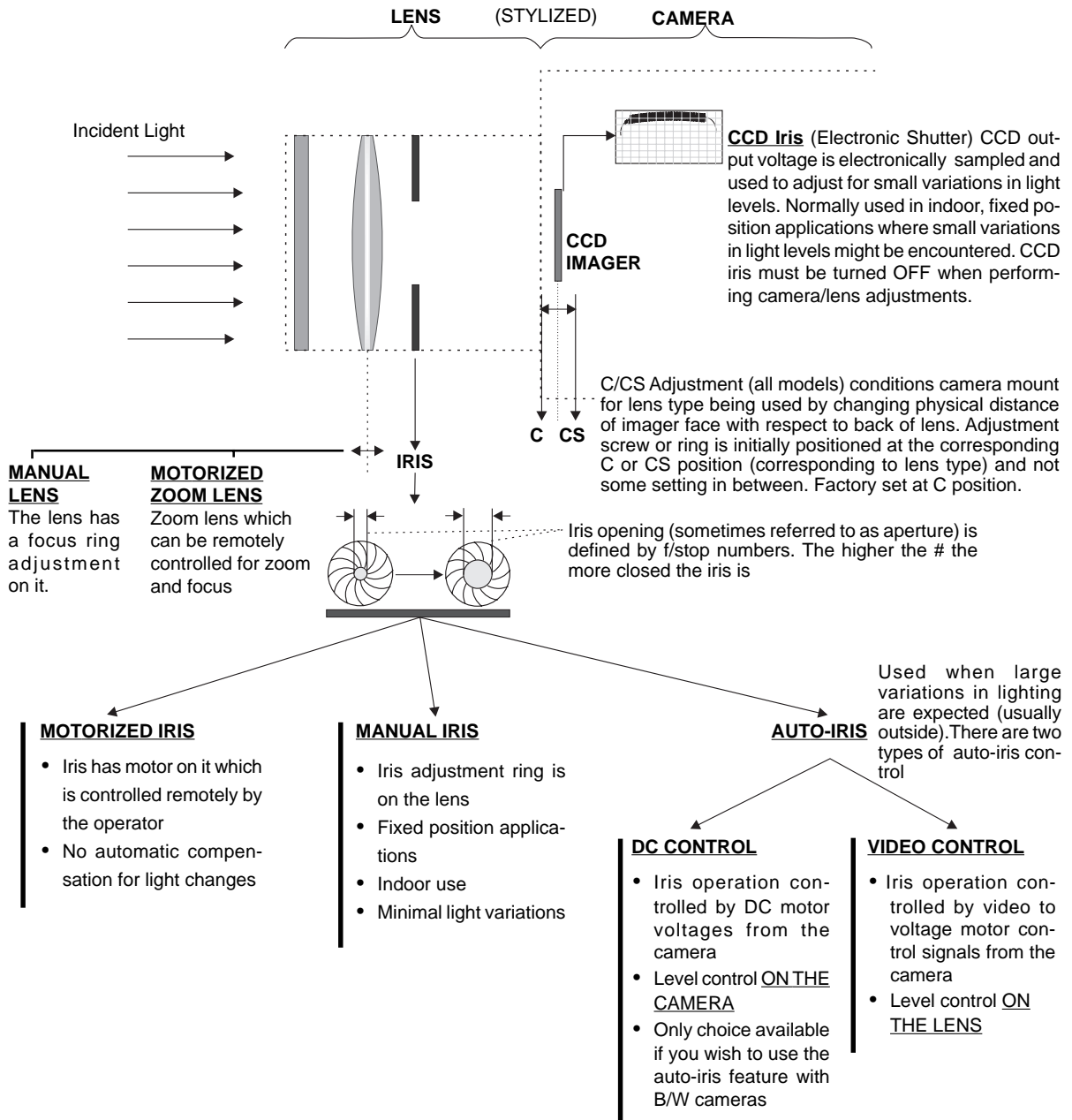

The purpose of backfocusing is to make the adjustments necessary for the picture to remain in focus throughout the camera's zoom range, which is the case for instance, in motorized zoom, auto iris configurations. Manual Iris lens/camera combinations also need to be backfocused. Follow the general instructions listed below to adjust backfocus appropriate to your camera/lens combination

LENS TYPE

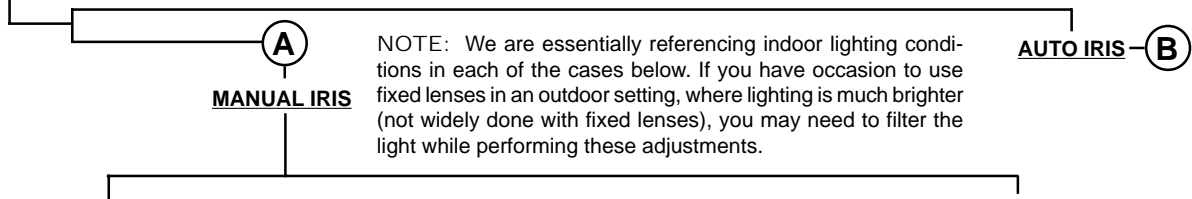

VARIABLE LIGHT CONDITIONS

- Turn **Manual Iris ring** so iris is fully open and set the **Focus ring** for ∞ (or distant object).

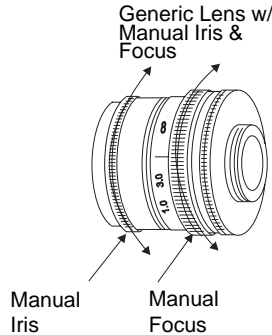

STATIC LIGHT CONDITIONS

- Adjust Backfocus the same as was done for Variable Light conditions except CCD iris is left in the OFF position; therefore there is no need to adjust the LVL control; follow all other steps, however.

- Set all other switches on the back of the Camera to the left (deactivated or OFF), including the **CCD Iris switch**.

CC3300 Series

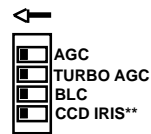

CC4600 Series

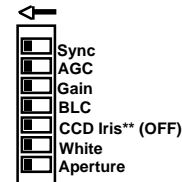

**With CCD Iris OFF, the Video Level control is inactive

- Adjust the **C/CS adjustment ring** for the best picture.

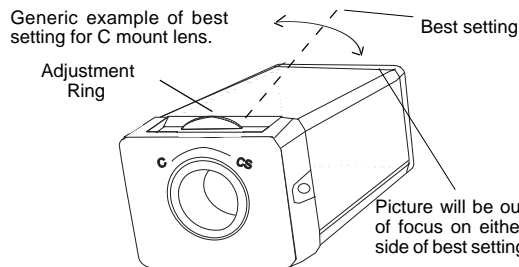

- Move **CCD Iris** switch to the **ON** position.

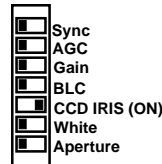
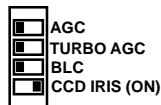

- Set the **Iris/Video Level** control pot to the **H** position.



- Adjust or set other camera switches as needed.

Backfocusing





Information Box

Lens/Camera Setup and Backfocusing

Information Box

The purpose of backfocusing is to make the adjustments necessary for the picture to remain in focus throughout the camera's zoom range, which is the case, for instance, in motorized zoom, auto iris configurations. Manual Iris lens/camera combinations also need to be backfocused. Follow the general instructions listed below to adjust backfocus appropriate to your camera/lens combination.

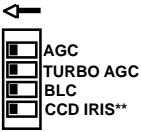
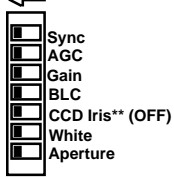
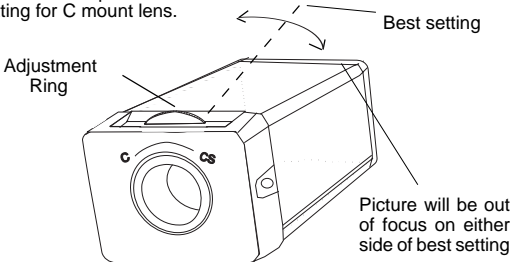
LENS TYPE

<p>NOTE: Most auto-iris configurations are associated with motorized zoom lenses, so the instructions below are based on that assumption</p>	
<p>B AUTO IRIS</p>	<p>A MANUAL IRIS</p>
<p>DC SERVO</p>	<p>VIDEO SERVO</p>
<p>CC3300 Series</p>	<p>CC4600 Series</p>
<p>AUTO IRIS VIDEO DC</p> 	
<ul style="list-style-type: none"> Make sure the Auto Iris/Video/DC switch is in the DC position. Use a neutral density filter or some other physical means to decrease the amount of light entering the camera lens so that the auto-iris response is to open the iris up as wide as possible. 	<ul style="list-style-type: none"> This step is the same as the one for DC SERVO, except that the AUTO IRIS VIDEO/DC switch is set to VIDEO, both models.
<p>AUTO IRIS VIDEO DC</p> 	
<ul style="list-style-type: none"> Set all other switches on the back of the Camera to the left (deactivated or OFF), including the CCD Iris switch. 	<ul style="list-style-type: none"> This step, same as for DC servo, both models.
	 <p>**With CCD Iris OFF, the Video Level control is inactive</p>
<h3>BACKFOCUS ADJUSTMENT</h3> <ul style="list-style-type: none"> Adjust focus to far, zoom to wide angle. Adjust C/CS adjustment Ring on the camera for the best picture. Zoom to a close object; adjust lens controller or focus for best picture. Repeat above until lens remains in focus throughout the zoom range (far to near). Tighten the Lock Screw. 	
<p>Generic example of best setting for C mount lens.</p>  <p>Adjustment Ring</p> <p>Best setting</p> <p>Picture will be out of focus on either side of best setting</p>	
<p>The ability of a zoom lens to remain in focus throughout its zoom range is known as Tracking</p>	
<ul style="list-style-type: none"> Finally, use the IRIS/VIDEO LEVEL adjustment on the REAR of the CAMERA to adjust for best picture Adjust other settings on camera as needed. 	<ul style="list-style-type: none"> For AUTO IRIS applications using VIDEO servo, set the IRIS/VIDEO LEVEL on the rear of the respective units to H.
<p>IRIS LEVEL</p>  <p>L H</p>	<p>VIDEO LEVEL</p>  <p>L H</p>

E

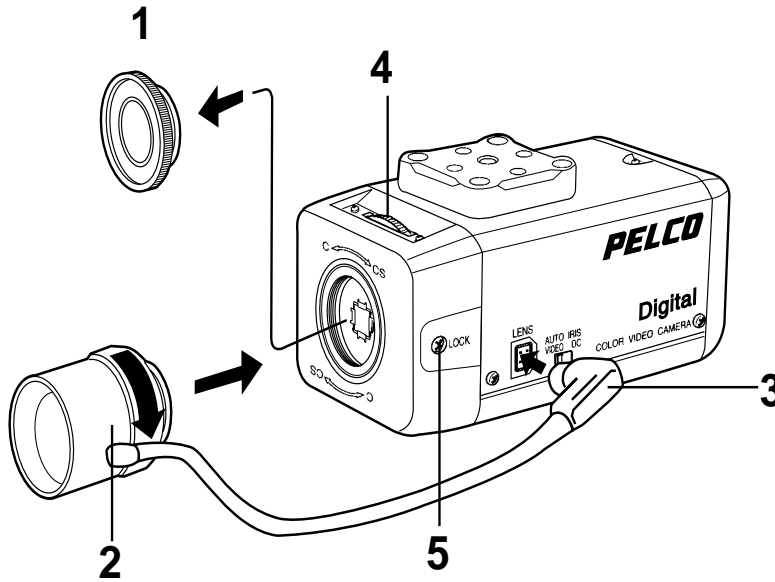

Fitting the Lens

CAUTION: When mounting the lens, loosen the securing nut on the side and turn the focal length adjustment to the C position. Mounting a C-mount lens with the adjustment ring in the CS position may damage the optical filter.



SA 1966

5.0 CAMERA INSTALLATION

ATTENTION: Installation should be performed by qualified service personnel only, in accordance with the National Electrical Code or equivalent/applicable local codes.

When attaching the camera to a ceiling bracket or tripod, attach the supplied mounting bracket. The bracket may be attached to either the top or bottom of the camera. Use the supplied 1/4" UNC-20 screw to attach the camera to the tripod or ceiling bracket.

5.1 Connections (Illustration **F**)

Using an internal synchronization signal.

- 1 Set the L.L./INT switch to "INT" (internal synchronization).
- 2 Connect with VIDEO OUT connector.
- 3 75-ohm coaxial cable
- 4 Connect with VIDEO IN connector on a video monitor, etc.
- 5 To power supply (CC4600-2, CC4600-2X); to a wall outlet (CC4600-3)
- 6 Power cord

- 7 To AC 24V terminals 1 and 2 (CC4600-2, CC4600-2X)

When using an external (L.L) synchronization signal, set the L.L./INT switch (1) to L.L. and make connections as above.



CAUTION: Be sure cable wires are routed so as to not pinch or rub when connected to pan/tilt units. Frayed, pinched or broken wires can cause fire/shock hazards or system failure.

5.2 Phase Adjustment (Illustration **G**)

When using more than one camera, connect to a camera switcher and set the vertical phase range as follows:

- | | |
|-------------------|--------------------|
| 1 Camera switcher | 3 Vertical phase |
| 2 Monitor | 4 Adjustable range |

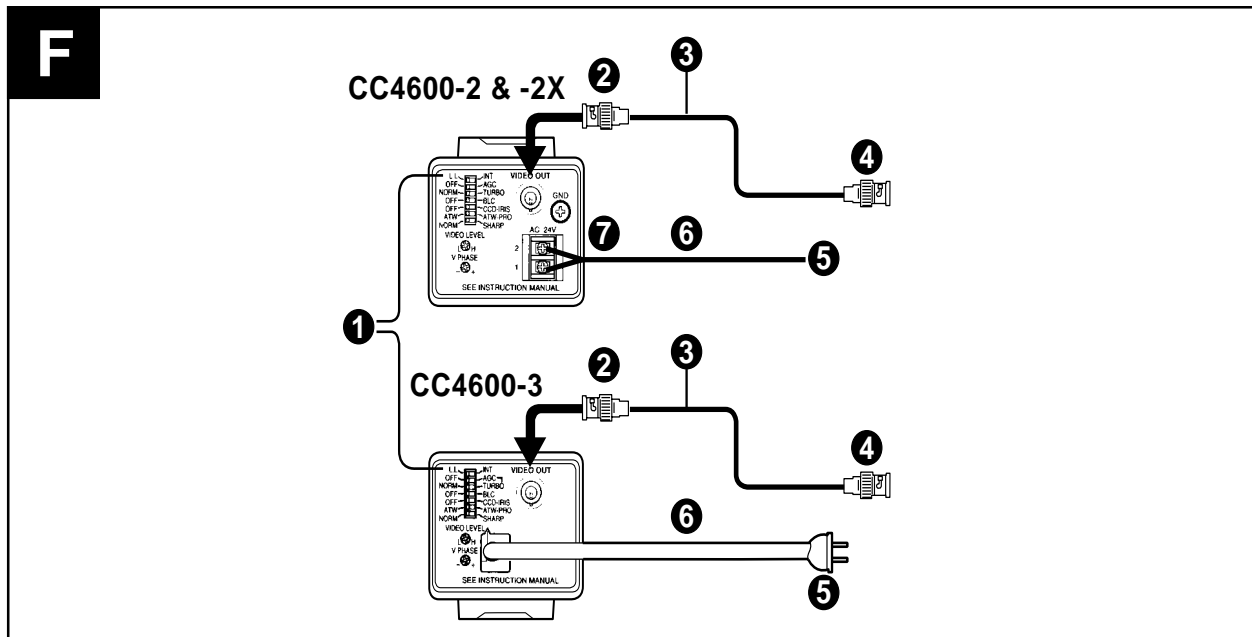

Connecting the CC4600 Series Cameras

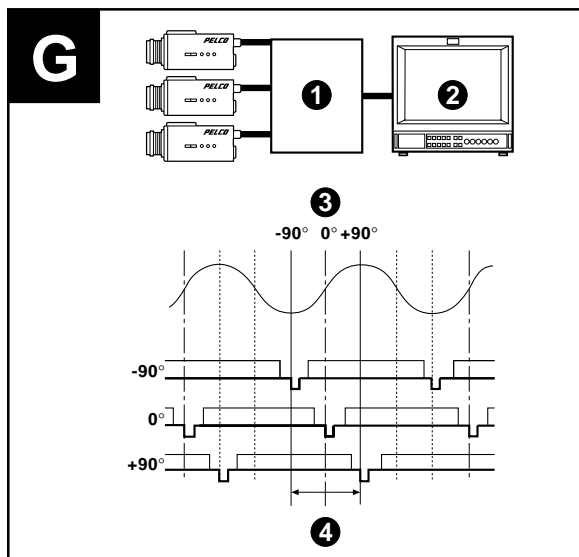

Phase Adjustment

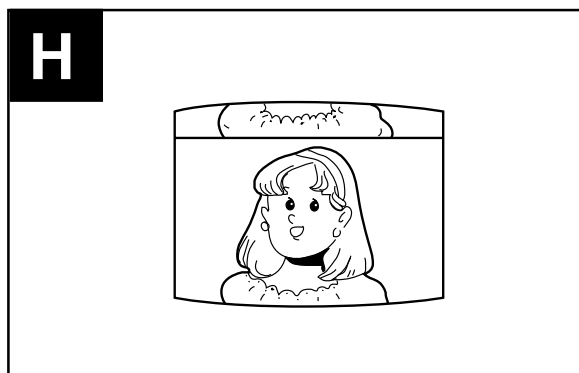

Vertical Phase

5.3 Vertical Phase (Illustration **H**)

Vertical phase adjustment is **NOT** vertical ROLL adjustment. Each camera is adjusted to the AC zero cross-over point at the factory. Problems arise, however, (especially in larger systems) when:

1. Switching rapidly between widely separated cameras with manual or sequential switchers.
2. Switching between cameras not operating off the same phase of the AC line.
3. Both of the above. There are other causes too (transformers wired backward, for instance) but the basic symptoms described below require V-phase adjustment.

In such cases, camera switching may produce what appears to be a vertical roll on the monitor between the two views. Turning the V Phase pot (while switching rapidly as possible between the two camera views) will adjust the relative phase angle between the two cameras and the point at which one camera synchronizes to the AC line with respect to the other. Adjust the pot until the switching is clean and there is no vertical roll or flip.

6.0 CCD CHARACTERISTICS

The following conditions which may be observed when using a CCD camera are not due to any fault within the camera.

Vertical smear - This phenomenon occurs when viewing a very bright object.

Patterned noise - This is a fixed pattern which may appear over the entire monitor screen when the camera is operated at a high temperature.

Jagged picture - When viewing stripes, straight lines, or similar patterns, the image on the screen may appear jagged.

7.0 HOUSEKEEPING

Be careful not to spill water or other liquids on the units, or allow combustible or metallic objects to fall inside the body. If used with foreign matter inside, the unit is liable to fail, or be a cause of fire or a shock hazard.

7.1 OPERATION AND STORAGE LOCATIONS

Do not aim the camera at very bright objects such as the sun or electric lights for an extended period. Avoid operating or storing the unit in the following locations:

- Extremely hot or cold places (operating temperature — 14° to 122° F [-10° to 50° C])
- Damp or dusty places
- Exposed to rain
- Exposed to strong vibration
- Close to generators of strong electromagnetic radiation such as radio or TV transmitters
- Exposed to fluorescent light reflections or unstable (flickering) lighting conditions

7.2 CARE OF THE UNIT

- Remove dust or dirt on the surface of the lens or CCD with a blower.
- Use a soft, dry cloth to clean the body. If it is very dirty, use a cloth dampened with a small quantity of a neutral detergent, then wipe dry.
- Avoid using volatile solvents such as thinner, alcohol, benzene and insecticides. They may damage the surface finish and/or otherwise impair the operation of the camera.

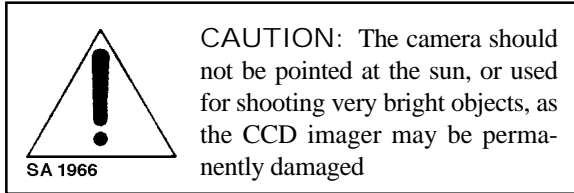

8.0 MAINTENANCE

These color cameras, as shipped, are factory adjusted and tested for optimum performance in most applications. No additional camera setup procedures should normally be required. However, improved performance may be obtained in some applications by field setup. Setup should be limited to the procedures described herein.

9.0 SPECIFICATIONS

Image Device: 1/3" interline transfer type CCD

Effective Picture Elements:

CC4600-2: 768 (horizontal) x 494 (vertical)

CC4600-2X/

CC4600-3: 752 (horizontal) x 582 (vertical)

Lens Mount: C-mount/CS-mount adjustable

Signal System:

CC4600-2: NTSC/EIA color system

CC4600-2X/

CC4600-3: PAL/CCIR color system

Synchronization

System: Internal/line lock

Horizontal

Resolution: 470 lines

Minimum

Illumination: 1.9 lux, F1.2 (with AGC set to ON in TURBO mode)

Video Output: 1 Vp-p, 75 ohm, negative sync

Video S/N: 50 dB (with AGC set to OFF)

White Balance: ATW/ATW PRO (switchable)

Automatic Gain

Control (AGC): Switchable: ON/OFF with Gain up (TURBO/NORM) switch in TURBO position and AGC ON, a 6 dB gain increase over NORM mode results.

Power Requirements:

CC4600-2: 24 VAC (60 Hz)

CC4600-2X: 24 VAC (50 Hz)

CC4600-3: 220-240 VAC (50 Hz)

Power Consumption:

CC4600-2/

CC4600-2X: Less than 4.5 W

CC4600-3: 5.5 W

Operating

Temperature: 14° to 122° F (-10° to 50° C)

Operating

Humidity: 20 to 80%

Storage

Temperature: -40° to 140° F (-40° to 60° C)

Storage

Humidity: 20 to 80%

Shock

Resistance: 70 G

Weight:

CC4600-2/

CC4600-2X: 550 g (1.20 lbs)

CC4600-3: 770 g (1.68 lbs)

Construction: Steel case

Finish: Neutral Gray

Dimensions: See Figure 6

Design and specifications are subject to change without notice.

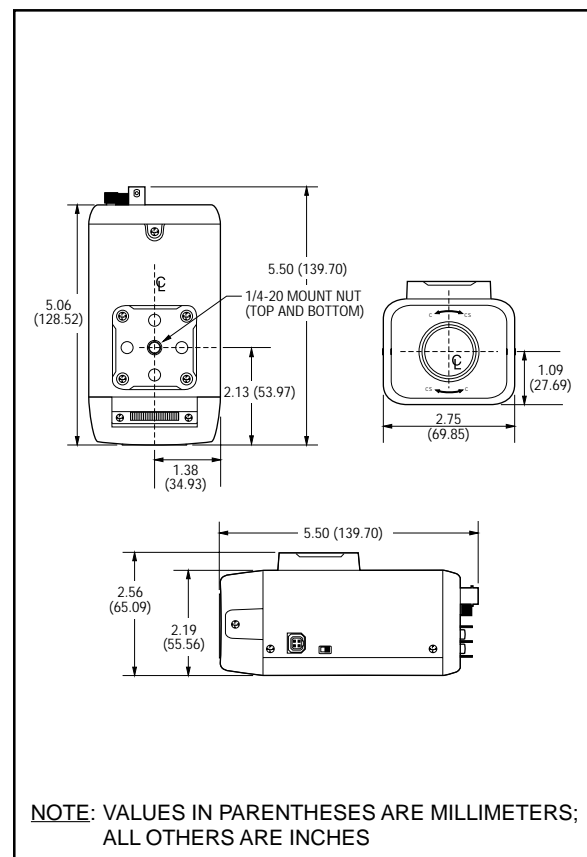

Figure 6. CC4600 Series Dimension Drawing

10.0 WARRANTY AND RETURN INFORMATION

PRODUCT WARRANTY AND RETURN INFORMATION

WARRANTY

Pelco will repair or replace, without charge, any merchandise proved defective in material or workmanship **for a period of one year** after the date of shipment.

Exceptions to this warranty are as noted below:

- Five years on FT/FR8000 Series fiber optic products.
- Three years on Genex® Series products (multiplexers, server, and keyboard).
- Three years on Camclosure® and fixed camera models, except the CC3701H-2, CC3701H-2X, CC3751H-2, CC3651H-2X, MC3651H-2, and MC3651H-2X camera models, which have a five-year warranty.
- Two years on standard motorized or fixed focal length lenses.
- Two years on Legacy®, CM6700/CM6800/CM9700 Series matrix, and DF5/DF8 Series fixed dome products.
- Two years on Spectra®, Esprit®, ExSite™, and PS20 scanners, including when used in continuous motion applications.
- Two years on Esprit® and WW5700 Series window wiper (excluding wiper blades).
- Eighteen months on DX Series digital video recorders, NVR300 Series network video recorders, and Endura™ Series distributed network-based video products.
- One year (except video heads) on video cassette recorders (VCRs). Video heads will be covered for a period of six months.
- Six months on all pan and tilts, scanners or preset lenses used in continuous motion applications (that is, preset scan, tour and auto scan modes).

Pelco will warrant all replacement parts and repairs for 90 days from the date of Pelco shipment. All goods requiring warranty repair shall be sent freight prepaid to Pelco, Clovis, California. Repairs made necessary by reason of misuse, alteration, normal wear, or accident are not covered under this warranty.

Pelco assumes no risk and shall be subject to no liability for damages or loss resulting from the specific use or application made of the Products. Pelco's liability for any claim, whether based on breach of contract, negligence, infringement of any rights of any party or product liability, relating to the Products shall not exceed the price paid by the Dealer to Pelco for such Products. In no event will Pelco be liable for any special, incidental or consequential damages (including loss of use, loss of profit and claims of third parties) however caused, whether by the negligence of Pelco or otherwise.

The above warranty provides the Dealer with specific legal rights. The Dealer may also have additional rights, which are subject to variation from state to state.

If a warranty repair is required, the Dealer must contact Pelco at (800) 289-9100 or (559) 292-1981 to obtain a Repair Authorization number (RA), and provide the following information:

1. Model and serial number
2. Date of shipment, P.O. number, Sales Order number, or Pelco invoice number
3. Details of the defect or problem

If there is a dispute regarding the warranty of a product which does not fall under the warranty conditions stated above, please include a written explanation with the product when returned.

Method of return shipment shall be the same or equal to the method by which the item was received by Pelco.

RETURNS

In order to expedite parts returned to the factory for repair or credit, please call the factory at (800) 289-9100 or (559) 292-1981 to obtain an authorization number (CA number if returned for credit, and RA number if returned for repair).

All merchandise returned for credit may be subject to a 20% restocking and refurbishing charge.

Goods returned for repair or credit should be clearly identified with the assigned CA or RA number and freight should be prepaid. Ship to the appropriate address below.

If you are located within the continental U.S., Alaska, Hawaii or Puerto Rico, send goods to:

Service Department
Pelco
3500 Pelco Way
Clovis, CA 93612-5699

If you are located outside the continental U.S., Alaska, Hawaii or Puerto Rico and are instructed to return goods to the USA, you may do one of the following:

If the goods are to be sent by a COURIER SERVICE, send the goods to:

Pelco
3500 Pelco Way
Clovis, CA 93612-5699 USA

If the goods are to be sent by a FREIGHT FORWARDER, send the goods to:

Pelco c/o Expeditors
473 Eccles Avenue
South San Francisco, CA 94080 USA
Phone: 650-737-1700
Fax: 650-737-0933